

Assembly Instructions

Item NO.:206-14-02-01-01

206-14-32-01-01

206-14-46-01-01



+ Parts Included

①



(1pc)

②

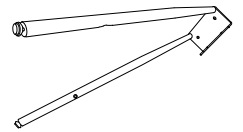

(1pc)

③

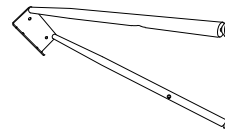

(1pc)

④

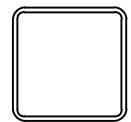

(1pc)

+ Do Not Use
Power Tools

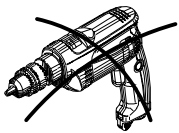

+ Suggested
Adults



NOTE: For questions about parts or assembly please email support@shankar.uk.com

1. Read instructions cover to cover.
2. Save all packaging until assembly is completed.

IMPORTANT ASSEMBLY INFORMATION

Assembly Step:

- 1) Use Screws to connect Part to Part.
- 2) Please strictly follow the assembly steps to assemble

+ Hardware Included

A



screw
M6*12(2pcs)

B



screw
M6*25(4pcs)

C



screw
M6*20(4pcs)

D



Allen Key
(1pc)

+ Do not tighten until all hardware is locked

Assembly Instructions

Item NO.:206-14-02-01-01

206-14-32-01-01

206-14-46-01-01

①

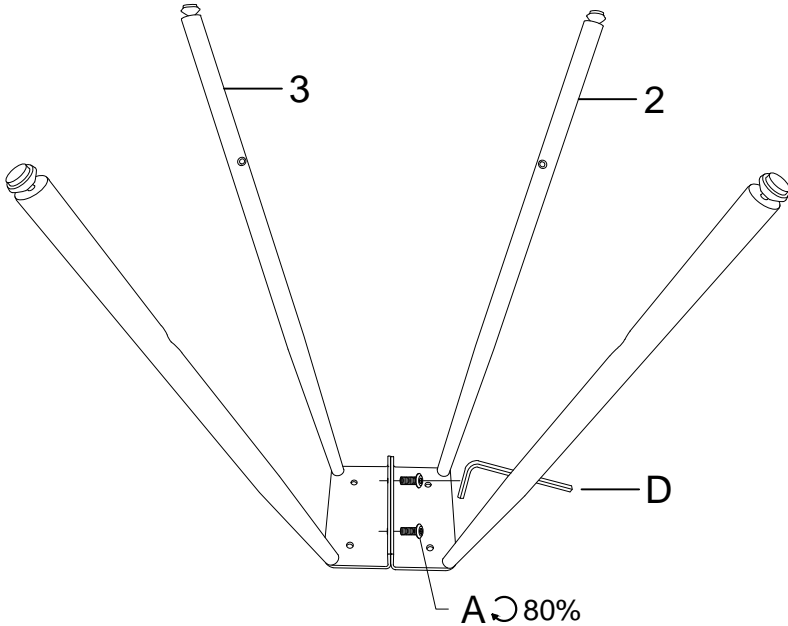

②

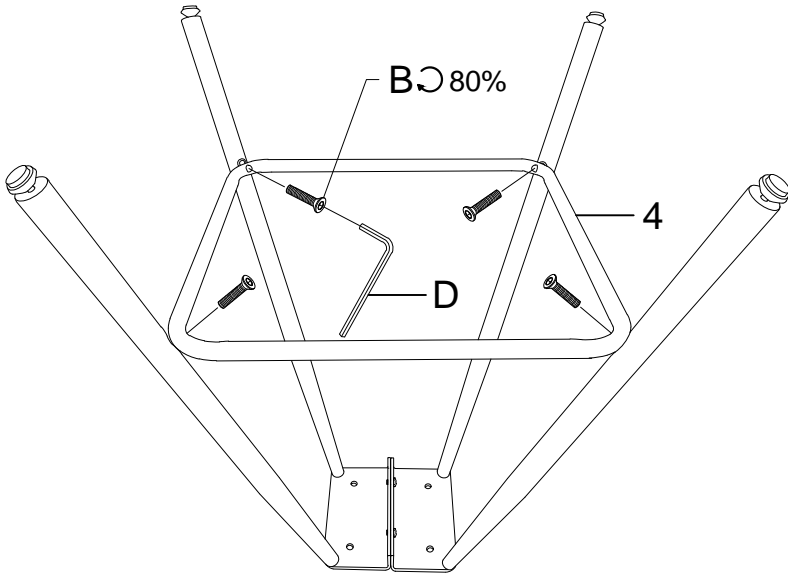

+ Do not tighten until all hardware is locked

Assembly Instructions

Item NO.:206-14-02-01-01

206-14-32-01-01

206-14-46-01-01

③

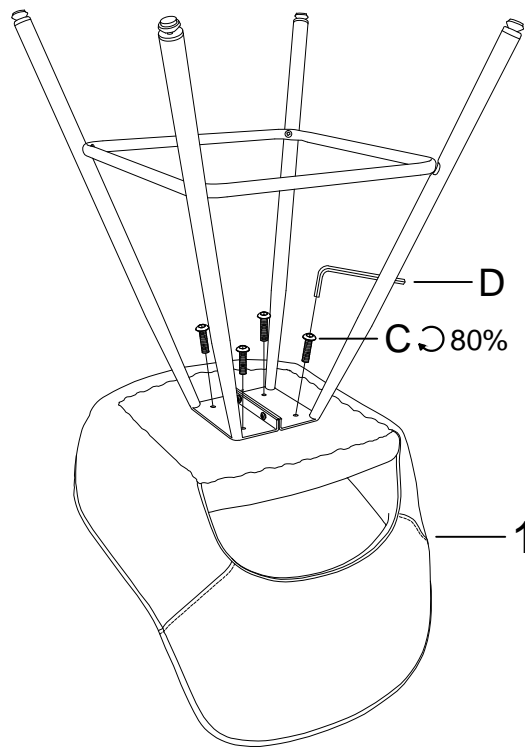

④

